

# AMW 140 IX

12NC: 858714001790

EAN code: 8003437211560



SENSING THE DIFFERENCE

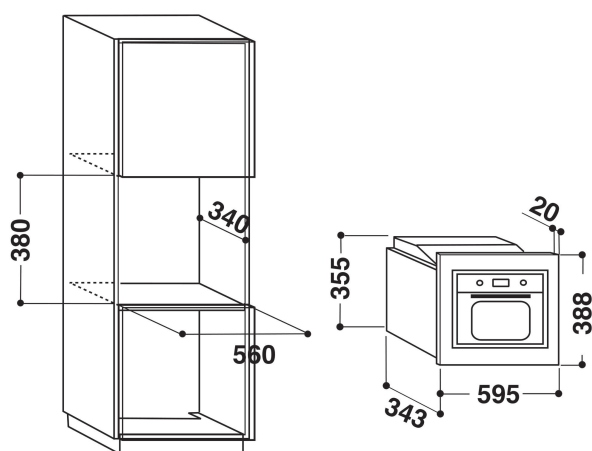

## MAIN FEATURES

Product group	Microwave
Commercial code	AMW 140 IX
Main colour of product	Inox
Type of micro-wave oven	MW+Grill function
Construction type	Built-in
Type of control	Electronic
Type of control setting and signalling devices	LED
Additional cooking method Grill	Yes
Crisp	No
Steam	No
Additional cooking method Fan cooking	No
Clock	Yes
Automatic programmes	No
Height of the product	388
Width of the product	595
Depth of the product	343
Minimum niche height	0
Minimum niche width	0
Niche depth	0
Net weight (kg)	15.35
Cavity capacity (l)	20
Turntable	Yes
Turntable diameter (mm)	245
Integrated Cleaning system	No

## TECHNICAL FEATURES

Current (A)	10
Voltage (V)	230
Frequency (Hz)	50
Length of Electrical Supply Cord (cm)	110
Plug type	Schuko
Timer	Minute minder
Grill power (W)	1000
Type of grill	Heating element
Cavity material	Stainless steel
Interior light	-
Additional cooking method Grill	Yes
Position of interior lights	Right side

## PERFORMANCES

6th Sense / Dynamic Intelligence	No
Number of power levels	5
Maximum micro-wave power (W)	800
Bread defrost	No
Jet defrost	Yes
Jet start	Yes